

Applied Geomorphology Lecture Notes

By David T. Allison

Topographic Maps

- Scale (Relational Fraction; Graphical)
- Elevation contours (Relative to M.S.L)
- Boundary (Latitude & Longitude)
- Color (Water bodies, Woodlands, etc.)
- Cultural Features (man-made features)

Scale

- Relational fraction
 - 1:24,000
 - 1 inch on the map = 24,000 inches in reality
 - 1 inch on the map = 24,000 inches x 1 foot/12 inches
 - 1 inch on the map = 2000 feet
 - 1 inch on the map = 2000 feet x 1 mile/5280 ft
 - 1 inch = 0.378 miles

Graphical Scale

- Uses a graphical scale to indicate distances

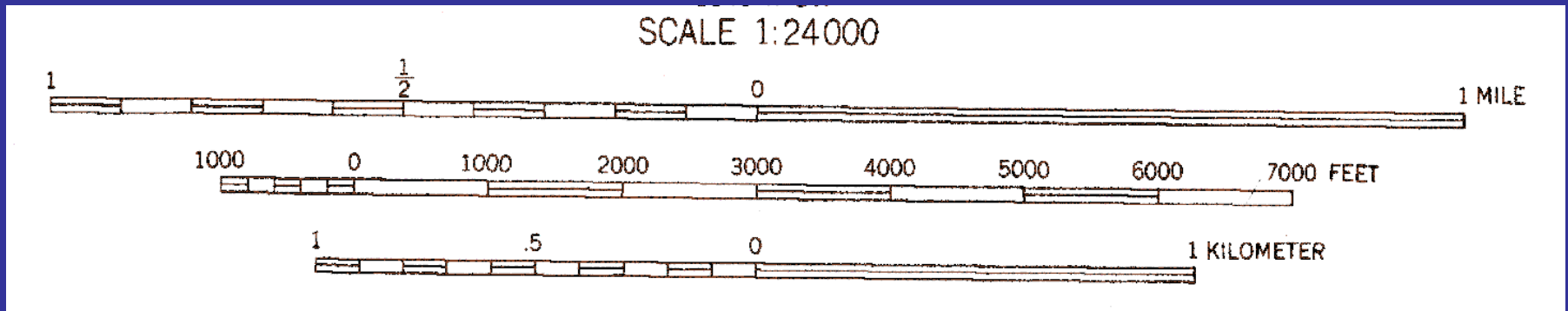

Elevation Contours

- Contour lines (brown)
 - Based on aerial photographs analyzed stereographically
 - Must agree with benchmarks and spot elevations
 - Contour interval: elevation change between adjacent contours
 - Hachured contours indicate closed depressions

Construction of Topographic Contours

- Contours of any parameter use a simple proportionality rule
- Contours should “V” in the upstream direction across valleys.



Topographic Map Boundary

- Always consist of lines of latitude and longitude
- Contain tick marks of UTM and SPCS on the border

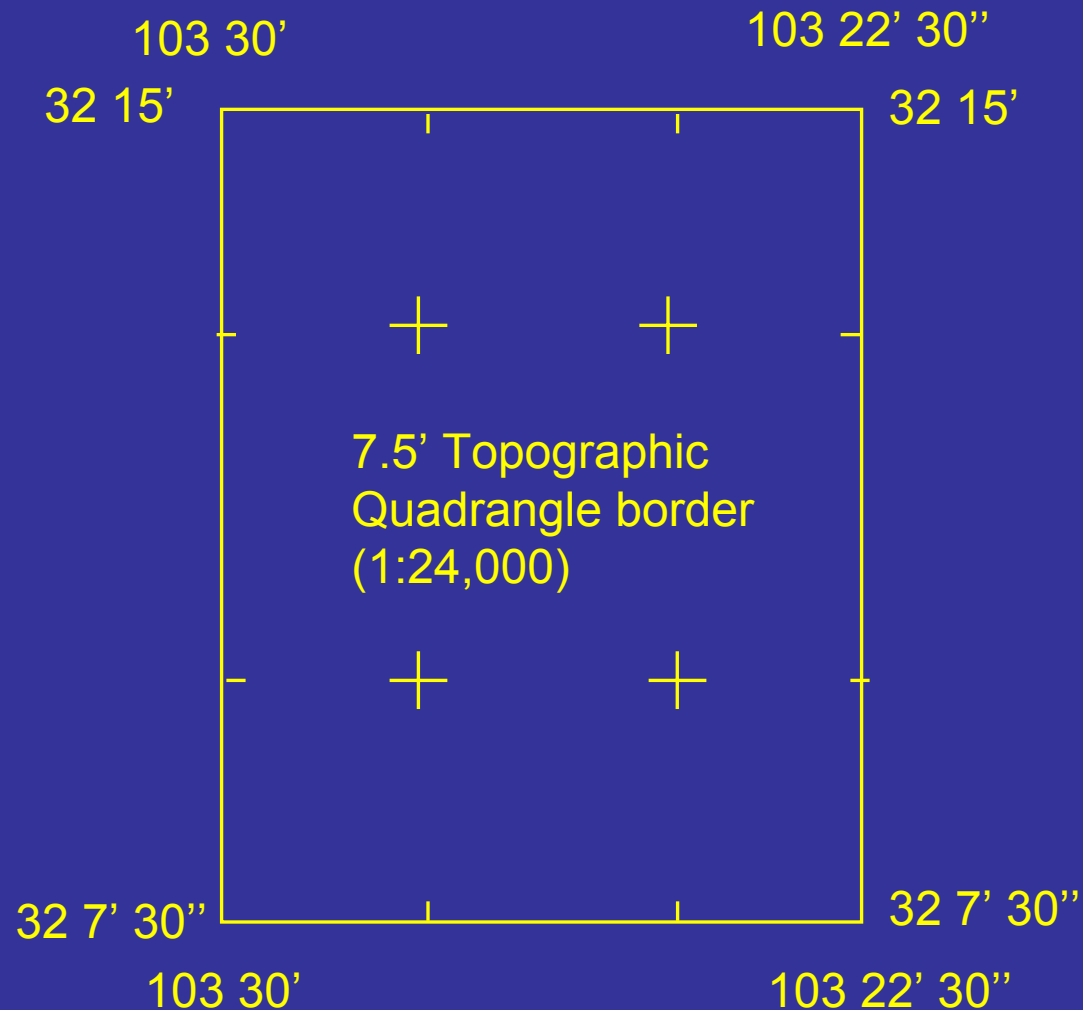

Topographic Map Colors

- Brown: topographic contours
- Green: Forest and/or wetlands
- White: cleared areas (i.e. pastures, etc.)
- Black: Cultural features (buildings, roads)
- Red: Land office grid system (Township & Range system); Major road systems
- Magenta: Photo-revised areas
- Blue: water bodies

Topographic Map Examples

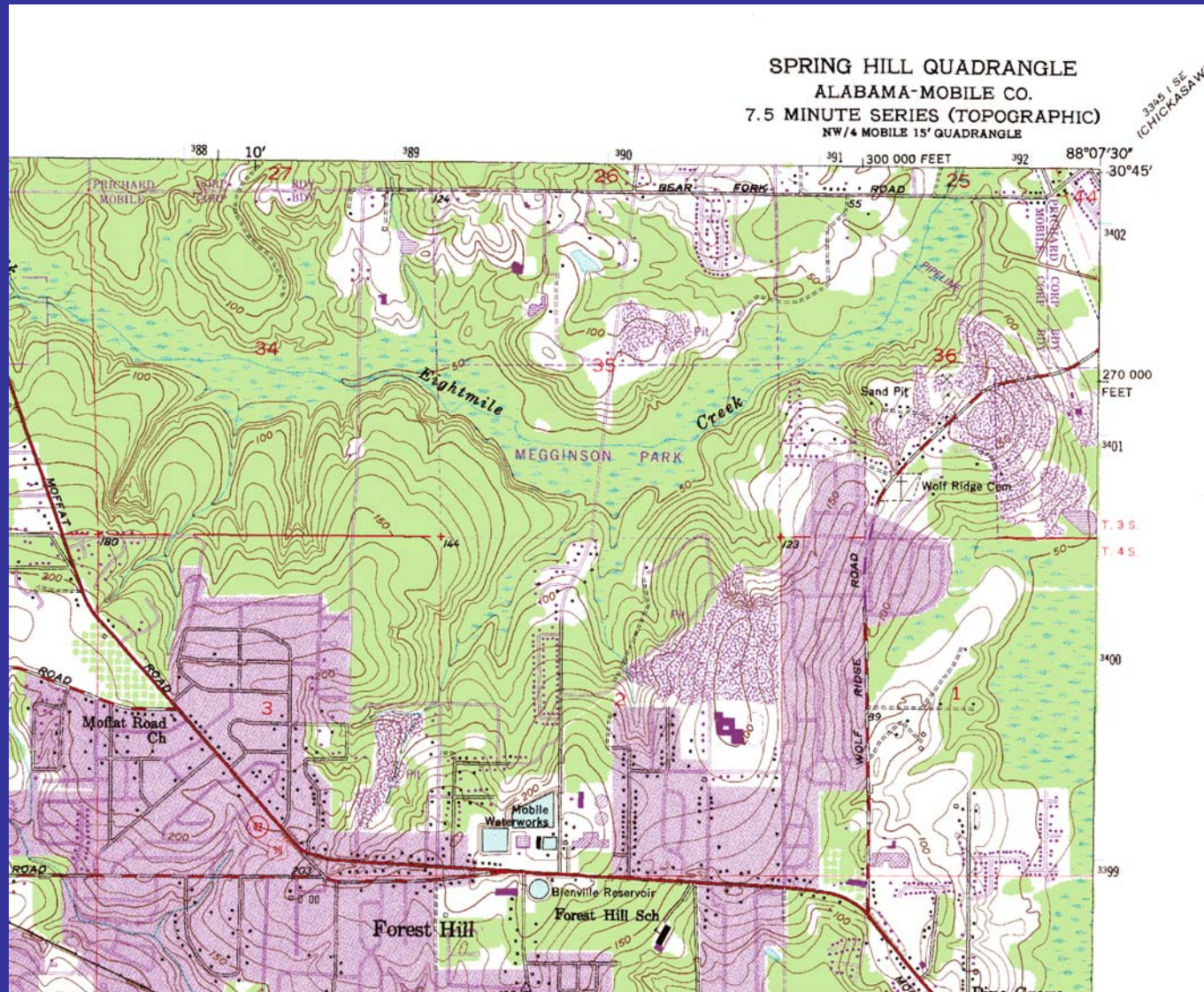

Map Coordinate Systems

- Land Office Grid system (Township & Range)
- Universal Transverse Mercator (UTM)
- State Plane Coordinate System (SPCS)

Land Office Grid System

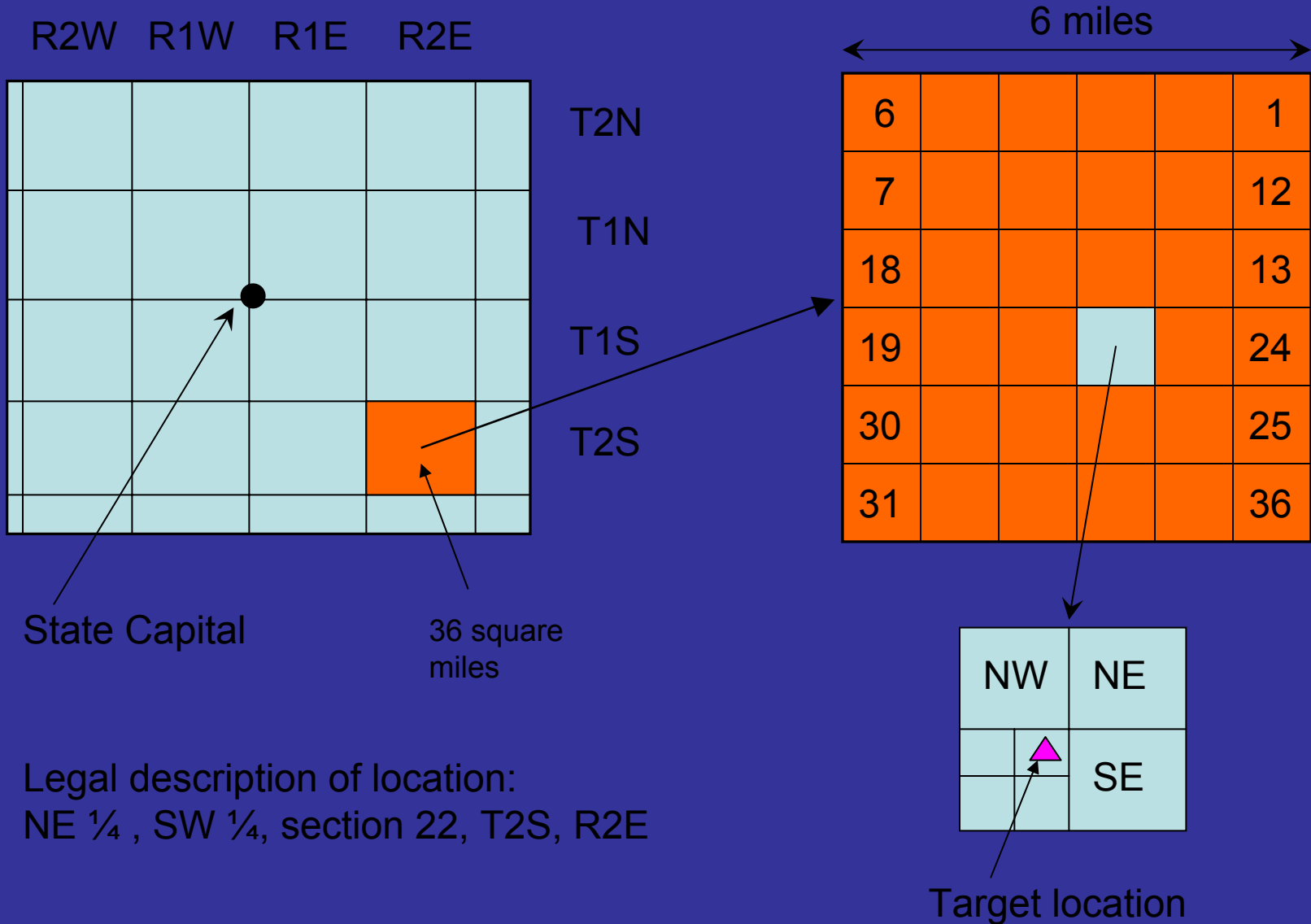

State Capital

36 square miles

Legal description of location:
NE $\frac{1}{4}$, SW $\frac{1}{4}$, section 22, T2S, R2E

Target location

Land Office Grid Example:

- Benchmark 212:
 - NW ¼, NE ¼, sec. 36, T3S, R3W

