

Applied Geomorphology

Lecture 3: Alidade & Plane Table methods



Alidade & Plane Table

- Used to make large scale maps (i.e. maps that show great detail over very small area, 1 inch = 10 feet is typical)
- Used to construct topographic maps where none exist
- Are ideal for contouring complex topography because the plane table allows for drawing the contours on-site



Parts of an Alidade

- 1: Telescope
- 3: Blade
- 4: Pedestal
- 6: Axis clamp screw
- 7: Tangent screw
- 8: Striding level
- 10: Fiducial edge
- 11: Bulls eye level
- 12: Azimuth adjustment
- 13: Compass box
- 14: Compass needle lever
- 15: Eyepiece
- 16: Stadia hairs
- 17: Eyepiece focus
- 19: Sun shade
- 20: lens cover
- 21: retaining ring
- 22: vertical angle level
- 23: vertical angle frame
- 24: vertical angle adjustment
- 25: Vernier scale
- 26: Vernier calibration mark

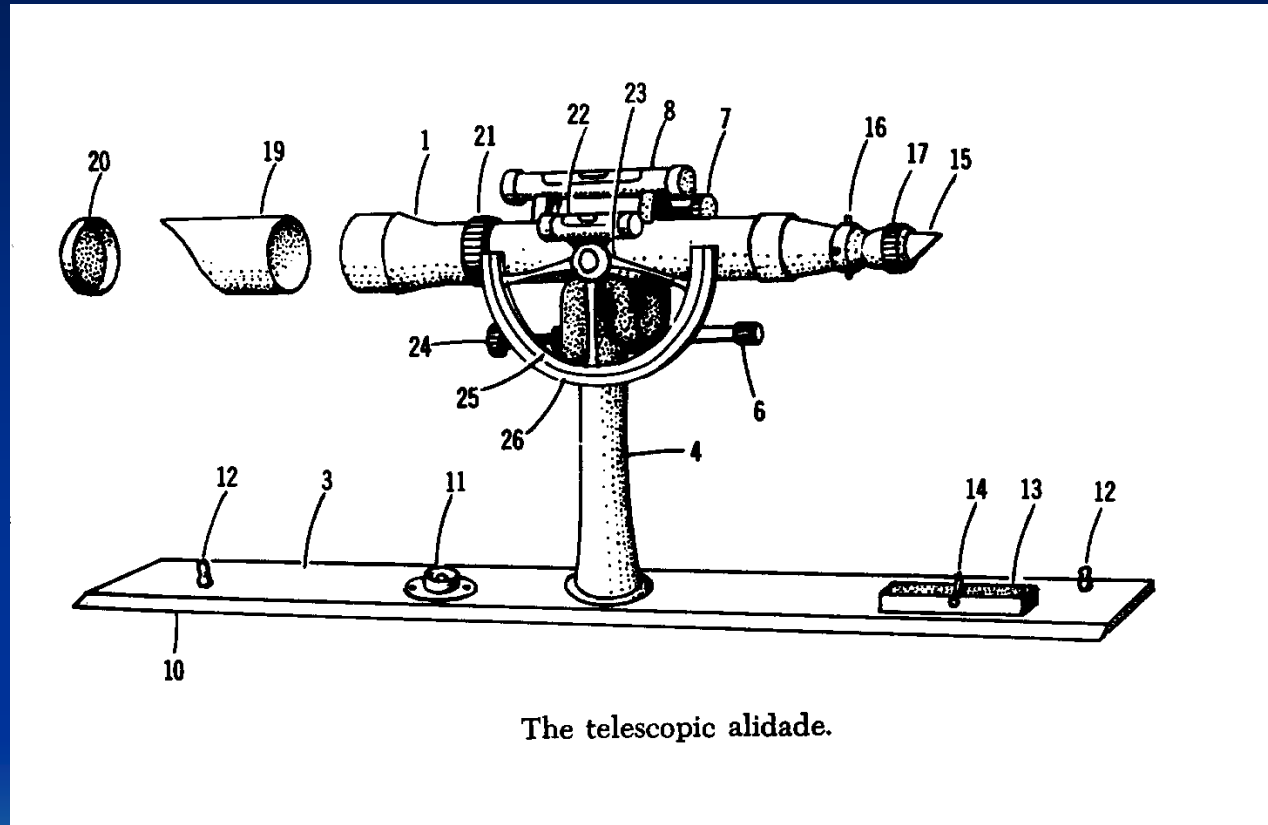

The telescopic alidade.

Measurements with the Alidade and Stadia Rod

- Stadia Rod: usually a 10 foot rod with feet and 0.1 foot divisions painted on the rod
- Setup of the instrument includes:
 - Leveling the plane table
 - Drawing magnetic north reference line
 - Measuring the instrument height
 - Making sure that the scale is recorded and that all features to be mapped will fit on map
 - Recording the elevation of the ground directly below the center of the plane table



Geometry of Alidade Measurements

- Stadia intercept: distance on rod from lower to upper horizontal stadia line; distance ratio is 1:100

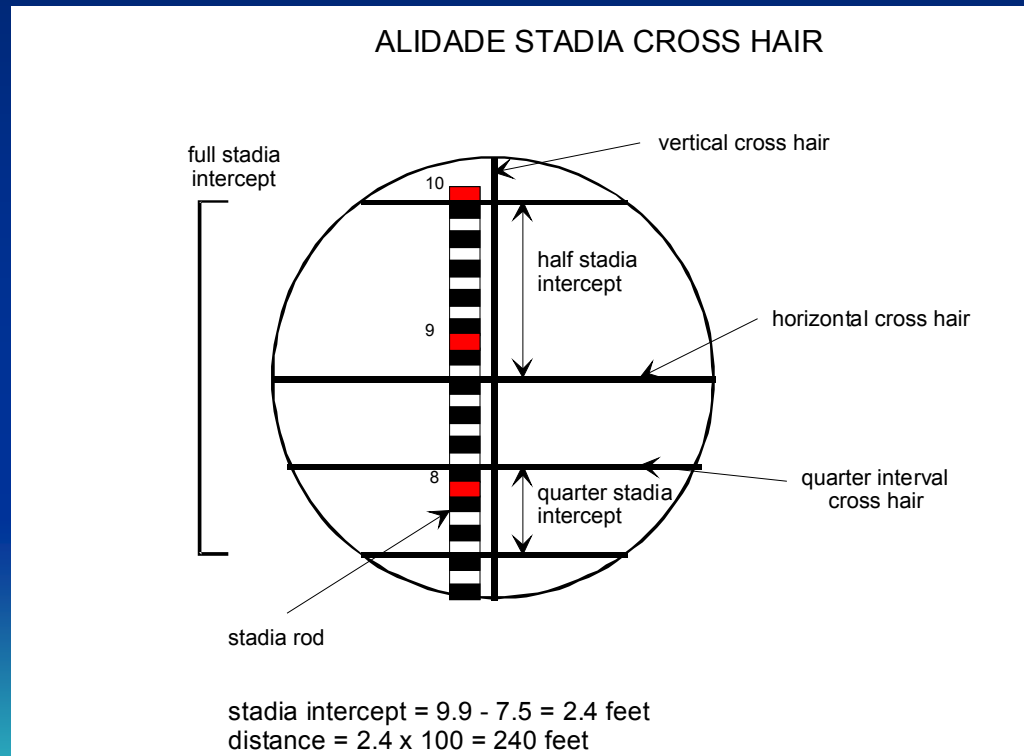

Geometry of Alidade Measurements cont.

- Vertical angle measurement with Vernier scale clinometer

ALIDADE VERTICAL ANGLE VERNIER

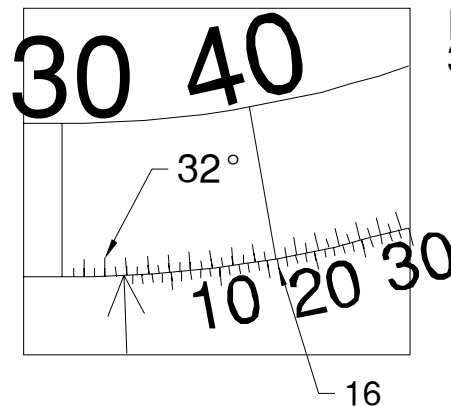
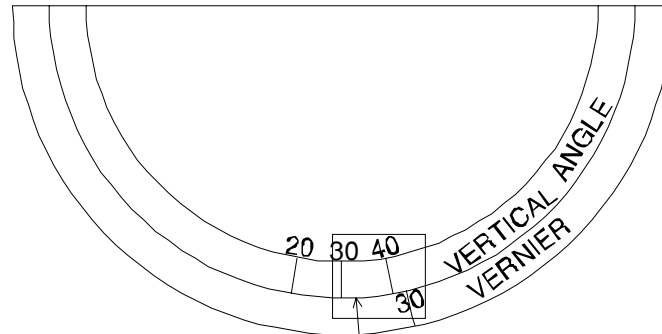

READING:
 $32^\circ 46' = 32.77^\circ$

Ray measurement Geometry

- Measurements from the alidade station to a data point are termed rays
- The ray is drawn on the plane table to track distance and direction, and the elevation of the ray endpoint is calculated in field notes
- A correction must be made for the difference between the alidade cross hair (CH) intercept and the instrument height (IH) of the alidade (see below):

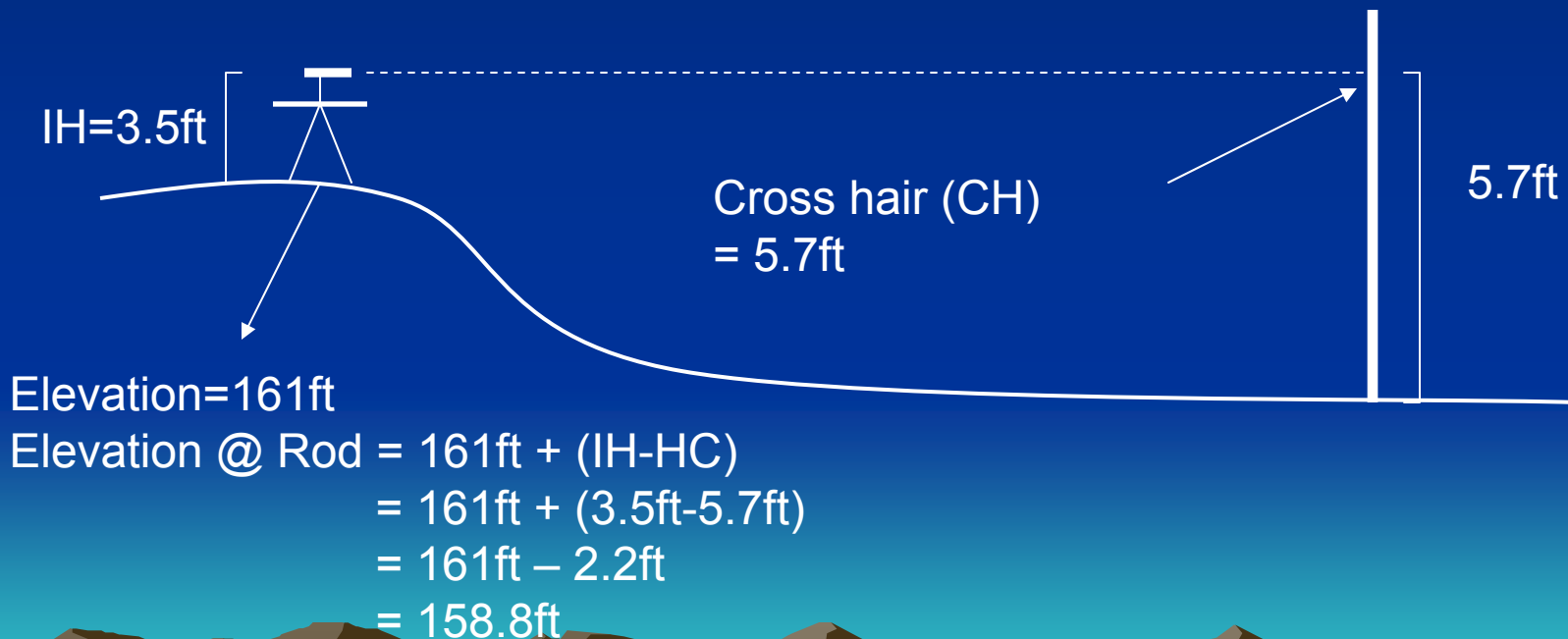

Ray Measurement Geometry cont.

- When slope angles and distances become large the alidade telescope must be inclined to view the stadia rod
- A trigonometric formula must be used to take the inclination of the telescope into account (see below):

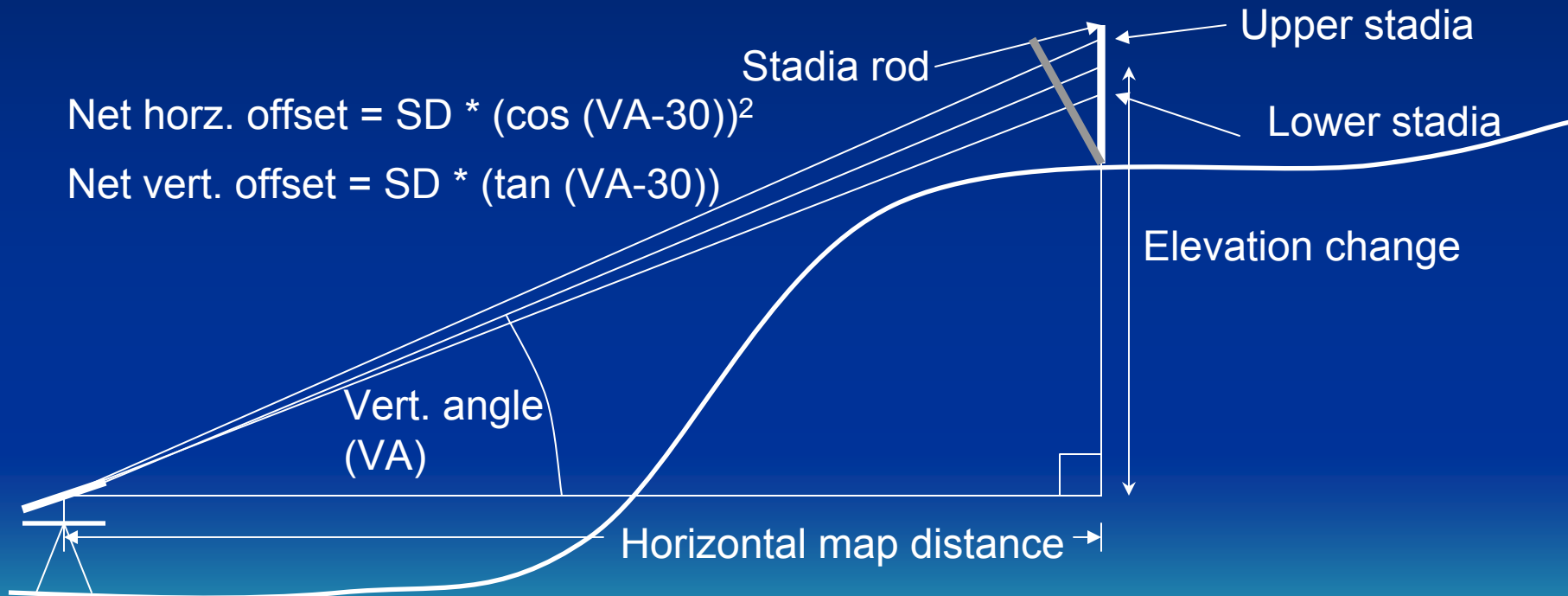

Worksheet for Alidade Data

- You must make the following measurements for each ray:
 - Stadia intercept: difference between upper and lower stadia hairs on the stadia rod
 - Cross hair intercept: where the central horizontal cross hair intersects the stadia rod
 - Vertical angle: vertical angle read from clinometer (including the Vernier scale)

Worksheet for Alidade Data								
Plane table site location description:								
Party and date:								
Plane table site elevation (SE):		161.10						
Instrument height (IH):		3.50						
	Stadia intercept	Stadia distance	Cross hair	Vertical angle	Net horz. dist.	Net elev. change (EC)	Rod elev.	
Rod point	SI	SD (1:100)	CH	VA	$SD * (\cos(VA-30))^2$	$SD * (\tan(VA-30)) + (IH-CH)$	SE+EC	NOTES
R-1	1.20	120.00	6.50	33.50	119.55	4.34	165.44	ray from 1st alidade station to tree #1
R-2	3.50	350.00	5.50	34.50	347.85	25.55	186.65	ray from 1st alidade station to tree #2
R-3	8.13	813.00	3.30	27.80	811.80	-31.03	130.07	ray from 1st alidade station to elevation control point



Alidade Mapping Strategy

- You should not try to shoot a ray $> 250\text{ft}$ with the alidade unless you have no choice
- Moving the alidade from one station to another station is “traversing” the instrument
- You should shoot rays to all needed control points around the 1st station, then shoot the last ray to the new 2nd station position
- You will need to calculate the elevation at the new 2nd site, and start a new data sheet with a new instrument height recording
- Since you are to produce a topographic map you may need supplemental elevation control points in addition to the feature that you are mapping (geological contact, building plan, etc.)

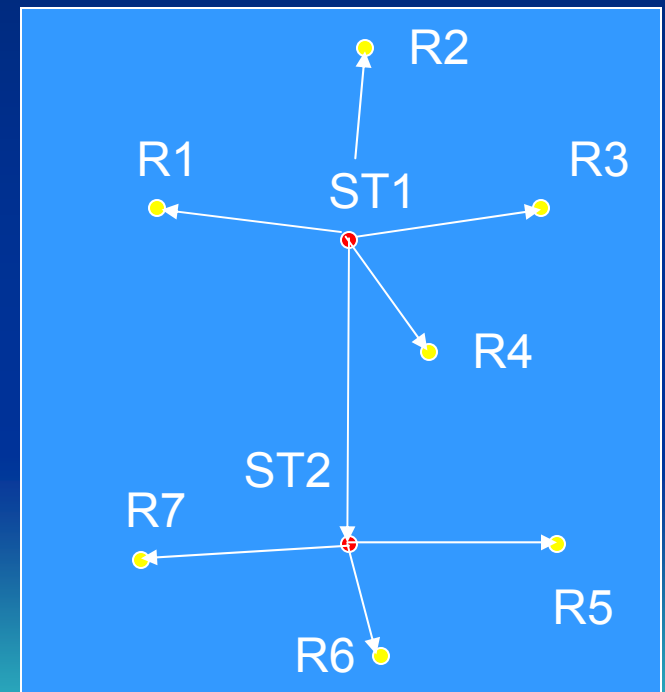

Baseline Triangulation

- By establishing a measured baseline objects can be accurately surveyed in terms of map position without stadia rods

